

# **SCHMEISER TILL AN' PAK™ AND ACCESSORIES**

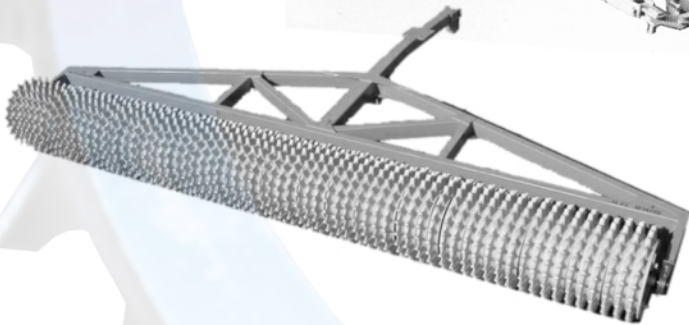
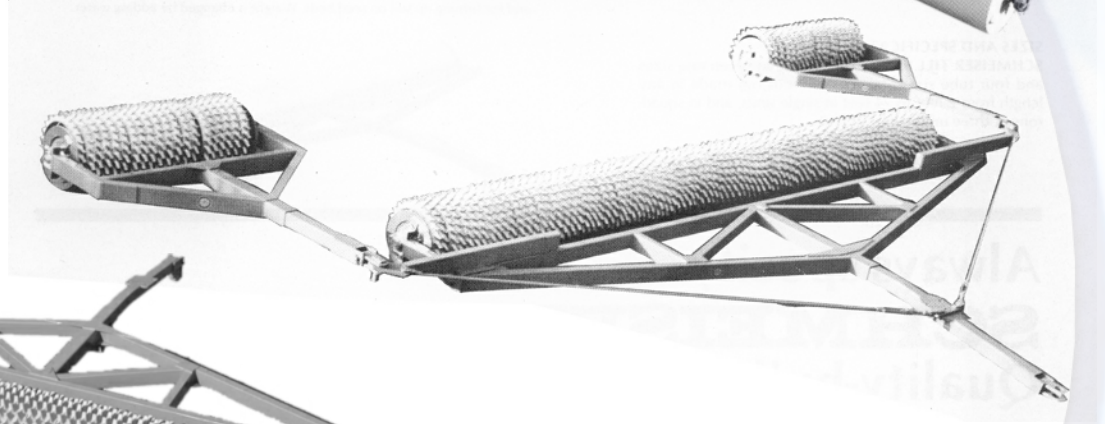

## **T. G. SCHMEISER OPERATION AND PARTS MANUAL**

Version 2.0  
July 2019

*Read and understand the manual. This manual provides information and procedures to safely operate and maintain the Till An' Pak*







## CONTENTS

<b>INTRODUCTION.....</b>	<b>4</b>	<b>MAINTENANCE.....</b>	<b>16</b>
Engineered for Long Life.....	4	Maintenance Schedule.....	16
Serial Number Information.....	4	Lubrication Points.....	17
Replacement Parts.....	4	Ground Engaging Components.....	17
Warranty Information.....	4	<b>STORAGE.....</b>	<b>17</b>
Serial Number Location.....	4	Storage Preparation.....	17
Factory Contact Information.....	4	Placing In Storage.....	17
Dealer Contact Information.....	4	Removing From Storage.....	17
Till An' Pak™ and Accessories.....	5	<b>PARTS SECTION.....</b>	<b>18</b>
<b>SAFETY.....</b>	<b>6</b>	Ordering Parts.....	18
Safety Alert Symbols.....	6	Till An' Pak Assembly.....	18
Safety Icons Nomenclature.....	7	Smooth An' Roll Assembly.....	19
Personal Protection/Important Information.....	7	Till An' Pak / Smooth An' Roll Tongue.....	20
Prohibited Actions.....	7	Till An' Pak Accessories.....	21
Hazard Avoidance.....	7	Float Assembly.....	21
General Safety.....	8	Squadron Arm Assembly.....	22
Assembly Safety.....	8	3-Point Hitch CA 1&2.....	23
Operation Safety.....	9	3-Point Hitch CA 2&3.....	24
Tractor Requirements.....	9	<b>LIMITED WARRANTY STATEMENT.....</b>	<b>25</b>
Tractor Safety Devices.....	10		
ROPS and Seat Belt.....	10		
Attaching to Tractor.....	10		
Maintenance Safety.....	11		
Bolt Torque Requirements.....	11		
Welding Repairs.....	11		
Storage Safety.....	11		
Disposal of Equipment at End of Useful Life.....	11		
<b>SAFETY SIGNS AND DECALS.....</b>	<b>12</b>		
Safety Sign Placement.....	12		
Safety Signs and Decals.....	13		
<b>OPERATION.....</b>	<b>14</b>		
Attaching to Tractor.....	14		
Initial Set Up Check List.....	14		
Implement Break-In.....	14		
General Operating Instructions.....	14		
Ring Roller Orientation.....	15		
Detaching From Tractor.....	15		

## INTRODUCTION

Your Schmeiser Till An' Pak (implement) is designed to provide many years of dependable service. This manual has been prepared to instruct the user in the safe and efficient operation of this implement. Read and understand the manual thoroughly and follow all instructions carefully.

### Engineered for Long Life

Our products are engineered to work in conjunction with other farm implements. The Till An' Pak helps save time and money when attached behind a plow or disc, seeder, fertilizer spreader, or fumigator.

### Serial Number Information

Record the serial number, model number, and date purchased in the space provided in the Serial Number Location section. Be sure to have this information whenever contacting the dealer to order parts or attachments for this implement.

### Replacement Parts

Should this implement require replacement parts, contact your local Schmeiser dealer. Always order genuine Schmeiser OEM replacement parts.

### Warranty Information

It is important that the Warranty Card be completed and sent to Schmeiser. The warranty will not be valid until the information is on-file at Schmeiser. If information not contained in this manual is needed, contact your Schmeiser dealer.

Thank you for buying a Schmeiser Till An' Pak.

## Serial Number Location

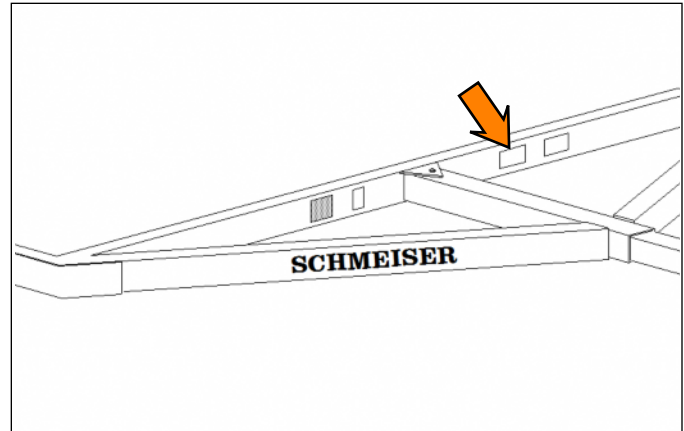

Serial No. \_\_\_\_\_

Model No. \_\_\_\_\_

Date Purchased. \_\_\_\_\_

Dealer Name. \_\_\_\_\_

### Factory Contact Information

For questions not answered in this manual, if additional copies are required, or the manual is damaged, please contact your local dealer or:

T. G. Schmeiser Co., Inc.  
P.O. Box 1392  
Selma, CA 93662

Phone: (559) 268-8128  
Fax: (559) 268-3279  
E-mail: [sales@tgschmeiser.com](mailto:sales@tgschmeiser.com)  
Web: [www.tgschmeiser.com](http://www.tgschmeiser.com)

Additional copies of this manual can also be downloaded at [www.tgschmeiser.com](http://www.tgschmeiser.com).

### Dealer Contact Information

For replacement decals, questions, or to order parts, contact your dealer:



## TILL AN' PAK™ AND ACCESSORIES

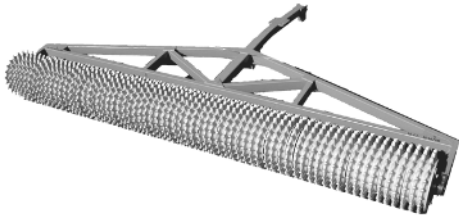

**TILL AN' PAK**

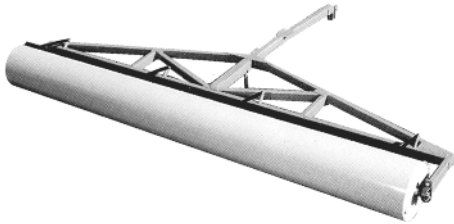

**SMOOTH AN' ROLL**

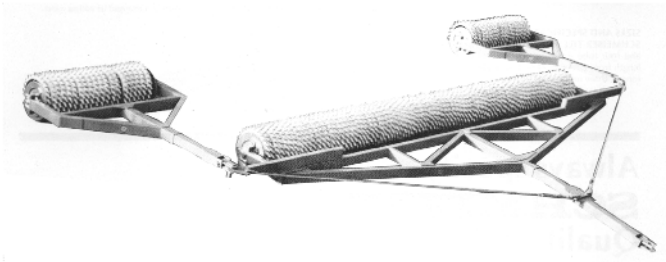

**SQUADRON ARMS**



**TILL AN' PAK FLOAT**



**3-POINT HITCH CATEGORY 1 & 2**

**3-POINT HITCH CATEGORY 2 & 3**

## SAFETY

The safe operation of any implement is an important concern to farmers and manufacturers. Safety of the operator and bystanders is one of the main concerns in designing and developing a new implement. There are obvious and hidden potential hazards involved in the operation of this implement. Carefully read and follow all safety precautions before operation. Serious injury or death may occur unless care is taken to ensure the safety of both the operator and any other persons in the area. Avoid potential danger by taking extra time for thought and a more careful approach to the use of this implement.

Most work related accidents are caused by failure to observe basic safety rules or precautions. An accident can often be avoided by recognizing potentially hazardous situations before an accident occurs. As you assemble, operate, or maintain the unit, you must be alert to potential hazards. You should also have the necessary training, skills, and tools to perform any assembly or maintenance procedures.

Improper operation and maintenance of this unit could result in a dangerous situation that could cause injury or death.

### WARNING



**Do not use or transport the unit until you read and understand the information contained in this manual.**



**Safety precautions and warnings are provided in this manual and on the unit. If these hazard warnings are not heeded, bodily injury or death could occur to you or to other persons.**

T.G. Schmeiser cannot anticipate every possible circumstance that might involve a potential hazard. The warnings in this manual and on the product are, therefore, not all-inclusive. If a method of operation not specifically recommended by us is used, you must satisfy yourself that it is safe for you and for others. You should also ensure that the unit will not be damaged or be made unsafe by the methods that you choose.

The information, specifications, and illustrations in this manual are based on the information that was available at the time this material was written and are subject to change without notice.

## Safety Alert Symbols



This is the safety alert symbol. It is used to alert you to potential personal injury hazards.

Obey all safety messages that follow this symbol to avoid possible injury or death.

This manual contains DANGERS, SAFETY INSTRUCTIONS, CAUTIONS, IMPORTANT NOTICES, and NOTES which must be followed to prevent the possibility of improper service, damage to the equipment, personal injury, or death. The following key words call the readers attention to potential hazards.

Hazards are identified by the "Safety Alert Symbol" and followed by a signal word such as "DANGER", "WARNING", or "CAUTION".

### DANGER

**Indicates an imminently hazardous situation which, if not avoided, will result in death or serious injury. This signal word is limited to the most extreme situations.**

### WARNING

**Indicates a potentially hazardous situation which, if not avoided, could result in death or serious injury.**

### CAUTION

**Indicates a potentially hazardous situation which, if not avoided, may result in minor or moderate injury.**

### NOTICE

**Indicates that equipment or property damage can result if instructions are not followed.**

### SAFETY INSTRUCTIONS

**Safety instructions (or equivalent) signs indicate specific safety-related instructions or procedures.**

**Note:** Contains additional information important to a procedure.

### Safety Icons Nomenclature

This manual and the equipment has numerous safety icons.

These safety icons provide important operating instructions which alert you to potential personal injury hazards.

### Personal Protection/Important Information

 READ THE MANUAL

 THINK SAFETY

 MAINTENANCE PROCEDURE

 WEIGHT RATING

 EYE PROTECTION

 HAND PROTECTION

 HEAD PROTECTION

 HEARING PROTECTION

 INSPECT EQUIPMENT

 OEM PARTS ONLY

 PLACE IN NEUTRAL

 PROTECTIVE SHOES

 REMOVE KEY

 DAMAGED HAZARD LABEL

 SLOW VEHICLE PLACARD

 SET PARKING BRAKE

 STOP ENGINE

 SUPPORT STAND USAGE

 USE PROPER TOOLS

 VISUALLY INSPECT

 USE ROPS

 USE CORRECT PARTS

### Prohibited Actions

 DO NOT ALTER OR MODIFY

 DO NOT LEAVE OUT TOOLS

 DO NOT WELD

 NO ALCOHOL

 NO CHILDREN

 NO DRUGS

 NO PASSENGERS

 NO RIDERS

 NO BYSTANDERS

### Hazard Avoidance

 BLOCK WHEELS

 CRUSHING HAZARD (body)

 CRUSHING HAZARD (foot)

 CRUSH HAZARD (rolling over)

 DEFECTIVE OR BROKEN PART

 FALLING HAZARD

 MAINTAIN SAFE DISTANCE

 OVERTURN HAZARD

 PINCH POINT HAZARD

 SAFETY ALERT SYMBOL

 SHARP OBJECT HAZARD

 ZERO PRESSURE

 COMPRESSED AIR HAZARD

 CRUSH HAZARD

 CRUSH HAZARD

 HIGH PRESSURE FLUID HAZARD

 HOT SURFACE HAZARD

 HEAVY OBJECT HAZARD



**GENERAL SAFETY**

**WARNING**



**Read and Understand Manual**

To prevent personal injury or even death, be sure you read and understand all of the instructions in this manual and other related OEM equipment manuals! This equipment is dangerous to children and persons unfamiliar with its operation. The operator should be a responsible adult familiar with farm machinery and trained in this equipment's operations. Do not allow persons to operate or maintain this unit until they have read this manual and have developed a thorough understanding of the safety precautions and how it works.

This unit was designed for a specific application; DO NOT modify or use this unit for any application other than that for which it was designed.

Units operated improperly or by untrained personnel can be dangerous!



**Fall Hazard**

Do not use this implement as a work platform. Do not stand on top of the unit at any time. Do not ride on the tractor or the implement or allow others to ride.



**Crush Hazard (Rolling Over)**

To prevent serious injury or death, before disconnecting, leaving the operator's seat, servicing, adjusting, repairing, or performing other work on the implement, ALWAYS:

1. Stop the tractor or towing vehicle.
2. Shut off the engine and remove the ignition key.
3. Set the brakes.
4. Make sure wheel cylinder transport lock is attached.
5. Relieve hydraulic fluid pressure.



**Injury Hazard**

Do not permit children to play on or around the unit.



**Impaired Operator Hazard**

Do not attempt to operate this unit under the influence of drugs or alcohol. Review the safety instructions with all users annually.



**Pinch Point /Sharp Object Hazard**

Do not place any body parts between moving and / or stationary parts. The weight of the implement will easily cause serious bodily injury.



**WARNING**



To prevent injury, use a tractor equipped with a Roll Over Protective System (ROPS).



**Visually Inspect**

Visually inspect the unit for any loose bolts, worn parts, or cracked welds, and make necessary repairs before using the unit.

**Personal Protection Equipment**

When working around or operating this unit, wear appropriate personal protective equipment. This list includes but is not limited to:



- A hard hat
- Protective shoes with slip resistant soles
- Protective goggles, glasses, or face shield
- Heavy gloves and protective clothing
- Ear muffs or plugs



**Use Properly Rated Tools**

To prevent serious injury: Use sufficient tools, jacks, and hoists that have the capacity for the job.



**NO PASSENGERS ALLOWED -**

Do not carry passengers anywhere on or in the tractor or implement.



**Rolling Hazard**

To prevent serious injury, lock the wheels when performing assembly, maintenance, repairs, or when preparing for storage.

**ASSEMBLY SAFETY**



**WARNING**



**Crush Hazard**

Use support blocks or safety stands rated to support the load when assembling the unit or performing maintenance. Never work under equipment supported by hydraulics. Hydraulics can drop equipment instantly if controls are actuated even when power to the hydraulics is shut off.



## OPERATION SAFETY



### WARNING



#### Crush Hazard (Rolling Over)

Do not clean, lubricate, or make adjustments while the unit is moving.



Never allow inexperienced or untrained personnel to operate the implement or tractor without supervision.



#### Enter And Exit Tractor

To avoid being run over, do not enter or exit tractor when it is moving. Avoid serious injury or death, from contact with rotating tires, by entering or exiting tractor only when it is completely stopped.



#### Safe Distance

Keep all bystanders, especially children, away from the tractor and implement during operation.



#### Overturn Hazard

Pick the most level route possible when transporting across fields. Avoid the edges of ditches, gullies, or steep hillsides. Be especially careful when turning on slopes with the wheels down. Never turn uphill with the wheels down except at slow speed and a low rate of turn. Never transport or operate this machine on steep slopes.

## SAFETY INSTRUCTIONS



Periodically clear the unit of brush, twigs, or other materials to prevent buildup of dry, combustible materials.



Visually check all fasteners for tightness or damage before and after operation. Repair immediately if required.

## Tractor Requirements



### WARNING



#### Tractor Owner/Operator Manual

Always refer to the tractor Operator's Manual to ensure compatibility and maximum safety.

Be familiar with the location, settings, and function of the tractor controls before using this equipment.

## SAFETY INSTRUCTIONS

Do not use a tractor of more than the recommended HP to prevent damaging implement components.

## Tractor Safety Devices

If transporting or operating the tractor and implement near a public roadway, the tractor must be equipped with proper warning lighting and a Slow Moving Vehicle (SMV) emblem, which are clearly visible from the rear of the unit. Lights and a SMV emblem must be attached directly to the implement if the visibility of the tractor warning signals is obscured.

Never operate the tractor PTO with the PTO master shield missing or in the raised position.

## ROPS and Seat Belt

The tractor must be equipped with a Roll Over Protective Structure (ROPS) (tractor cab or roll-bar) and seat belt to protect the operator from falling off the tractor, especially during a roll-over where the driver could be crushed and killed.

Only operate the tractor with the ROPS in the raised position and seat belt fastened.



### WARNING



#### Rollover Hazard

To avoid serious injury or death from falling off tractor, equipment runover, rollover, or crushing:

- 1) Use ROPS equipped tractor.
- 2) Keep ROPS locked in the UP position.
- 3) Only operate the equipment when seated in the tractor seat.
- 4) Always fasten seat belt when operating the tractor and Implement.

## Attaching to Tractor

### Prior to Connecting Unit

Make sure the unit is resting on the ground or the transport lock is securely installed over the wheel cylinder rod before attaching the unit to the tractor.

**Connecting to Tractor**

**WARNING**



**Crush Hazard**

Use care when attaching the unit to the tractor. Never place any part of your body under the tongue or hitch assembly. Do not allow anyone to stand between the hitch and implement during hook-up operations.



**Unexpected Separation Hazard**

If towing the unit with a drawbar, use only a certified, hardened drawbar pin with a retainer clip. Do not use homemade pins, bolts, or any other type of retaining device. Always install the retainer clip, making sure the hitch and unit are securely fastened to the tow vehicle. Using a pin not intended for this type of towing can result in unexpected separation of the unit from the tow vehicle, resulting in equipment damage and personal injury.

**SAFETY INSTRUCTIONS**

Connect implement hitch to the tractor properly.

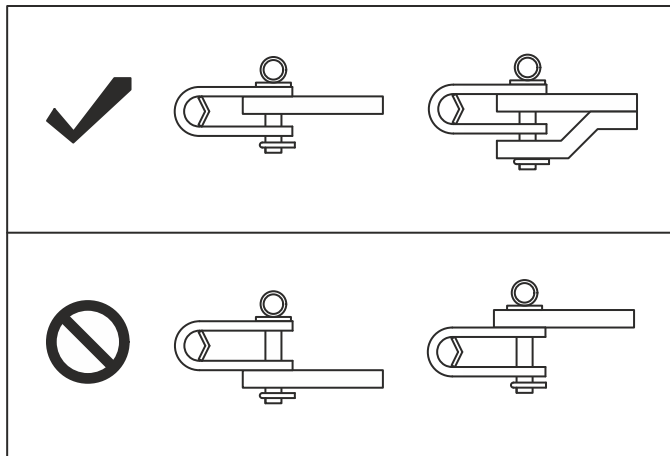

**MAINTENANCE SAFETY**

**WARNING**



**Use Properly Rated Tools**

Use sufficient tools, jacks, and hoists that have the capacity for the job.



**Crush Hazard**

Use support blocks or safety stands rated to support the load when performing maintenance.

**SAFETY INSTRUCTIONS**

Follow all operating, maintenance, and safety instructions found in this manual.



Understand the service procedure before performing the work. Keep area clean and dry.



Keep all parts in good condition and properly installed. Fix damage immediately. Replace worn or broken parts.



Do not leave tools lying on the unit.



Do not modify unit or safety devices. Do not weld on the unit. Unauthorized modifications may impair its function and safety.

If equipment has been altered in any way from the original design, the manufacturer does not accept any liability for injury or warranty.



Never replace hex bolts with less than Grade 5 bolts unless otherwise specified. In locations where Grade 8 bolts are used, Grade 8 replacements are required.



Where replacement parts are necessary for periodic maintenance and servicing, genuine factory replacement parts must be used to restore the unit to original specifications.

The manufacturer will not accept responsibility for damages as a result of the use of unapproved parts.

### Bolt Torque Requirements

It is extremely important to apply and maintain proper torque on all bolts. Use a torque wrench to assure the proper amount of torque is being applied to the fastener. Start all bolts or nuts by hand to prevent cross threading.

Torque figures indicated in the chart are used for non-greased or non-oiled threads unless otherwise specified. Therefore, do not grease or oil bolts or cap screws unless otherwise specified in this manual. When using locking elements, increase torque values by 5%.

The chart gives correct torque values for various bolts and cap screws. Tighten all bolts to the torques specified in the chart unless otherwise noted. Check tightness of bolts periodically, using the bolt torque chart as a guide. Always replace hardware with the same Grade bolt.

### WARNING



#### Equipment Failure

The torque value for bolts and cap screws are identified by their head markings. Replacing higher "Grade" bolts (Grade 5) with lower grade bolts will lead to equipment failure and can result in injury or death. Always use replacement bolts with the same Grade markings as the removed bolt.

Bolt Diameter	Bolt Torque Specifications			
	Grade 5		Grade 8	
	N·m	ft.lbs.	N·m	ft.lbs.
1/4"	12	9	17	12
5/16"	25	19	36	27
3/8"	45	33	63	45
7/16"	72	53	100	75
1/2"	110	80	155	115
9/16"	155	115	220	165
5/8"	215	158	305	220
3/4"	390	290	540	398
7/8"	570	420	880	650
1"	850	630	1320	970

### Welding Repairs



Before performing any type of welding repair to the implement, contact T.G. Schmeiser Co., Inc. for approval. Repair welding must be done with care and with procedures that may be beyond the capabilities of the ordinary welder.

### WARNING



#### Personal Injury Hazard

Repairs or modifications to the implement can result in serious injury or death should these repairs fail.

### NOTICE

Anyone performing a welding repair should be certified in accordance to the American Welding Society (AWS) standards.

### STORAGE SAFETY

### WARNING



#### Hazard And Information Signs

Replace any missing or hard-to-read safety signs. Safety sign placement and part numbers can be found in the Nomenclature section of this manual.



#### Damaged Parts Hazard

Do not use this unit if it is in need of repair. If you believe the unit has a defect which could cause damage, injury, or death, you should immediately stop using the unit.

### SAFETY INSTRUCTIONS



Store the implement in an area away from human activity.



Do not permit children to play on or around the stored unit at any time.



Block the wheels to prevent the implement from rolling.



When using compressed air to clean implement, wear safety glasses.

### DISPOSAL OF EQUIPMENT AT END OF USEFUL LIFE

The T. G. Schmeiser has been designed implement for the specific purpose of conditioning the ground in agricultural applications. When this unit is no longer capable of doing its designed purpose, it should be dismantled and scrapped. Do not use any materials or components from this unit for any other purpose.

## SAFETY SIGNS AND DECALS

### SAFETY INSTRUCTIONS



#### Replace all worn or damaged safety and instruction decals.

- It is the responsibility of the customer to know the marking requirements of the local highway authorities and to comply with the regulations.
- Keep safety signs clean and legible at all times. Replace safety signs that are missing or have become illegible.
- Do not paint over, remove, or deface any safety signs or instructional decals on your equipment. Observe all safety signs and follow the instructions on them.

- When parts that display a safety sign are replaced, the replacement part should display the same sign.
- Make sure the safety signs and other instructional decals are legible and attached to the unit before use.
- Safety signs are available from your Distributor, Dealer Parts Department, or the factory.
- Use care when washing or cleaning the unit not to remove or damage the labels.
- Locations for the labels and replacement part numbers are shown in this section.

### Safety Sign and Decals Placement

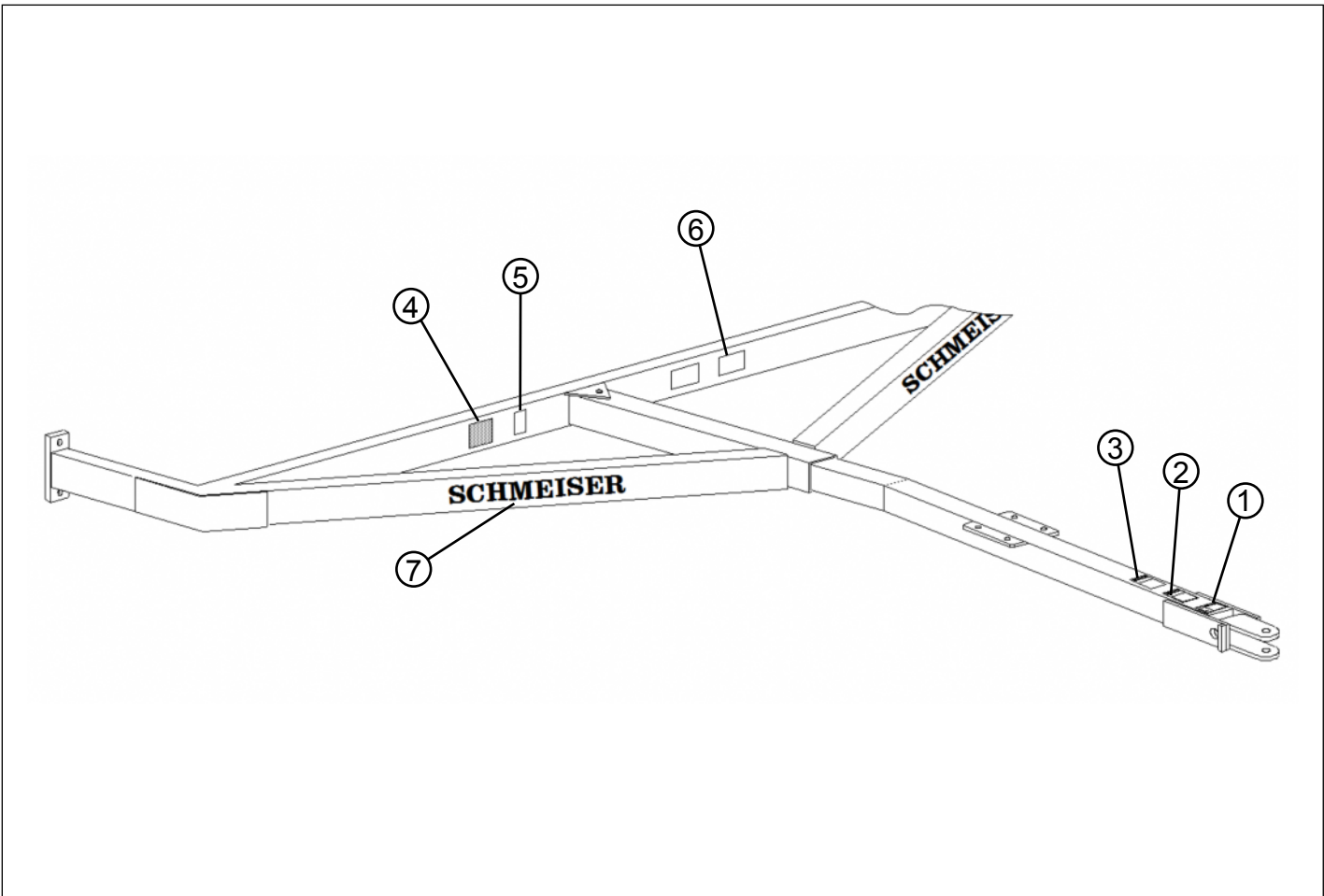

**Safety Signs**

Item	Part Number	Description	Qty.
1	D28X048PPT	Pinch Point	1
2	D48X038RTM	Read the Manual	1
3	D48X038CRR	Crush / Rollover Hazard	1
4	D48X48QR	Scan to Access Online Manual	1
5	—	FEMA	1
6	D32X048RBC	Made in the USA	1
7	D32X208TGS	Schmeiser (13")	2



4.

D48X48QR

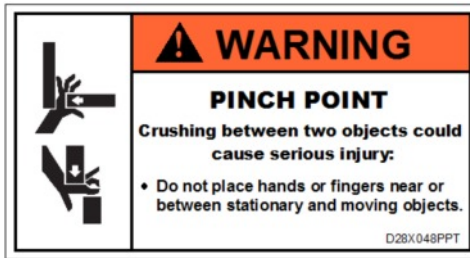

1.

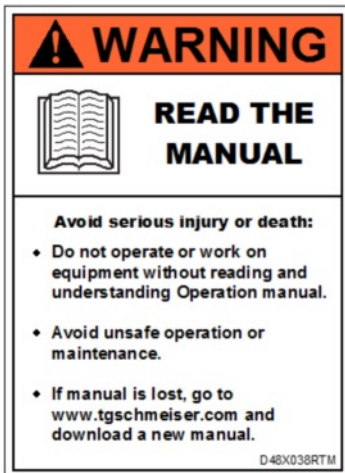

2.

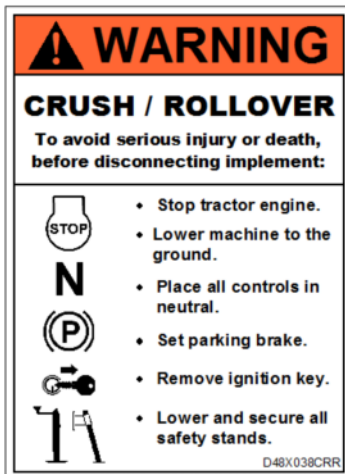

3.



5.



6.

D32X048RBC



7.

D32X208TGS



## OPERATION

### **WARNING**



#### **Understand Safety Procedures!**

Read and understand all safety procedures described in this manual before performing any work on or around the implement.



### Attaching to Tractor

Use caution when connecting the Till An' Pak to the tractor. The Till An' Pak should be securely resting on the ground. Keep hands and feet from under the implement and clear of pinch points between the tractor drawbar and implement hitch.

### Initial Setup Checklist

Efficient and safe operation of the Till An' Pak requires that every user read and understand the operational instructions and all related safety instructions outlined in this manual.

This checklist is provided for the user/owner. It is important for both personal safety and to maintain the mechanical condition of the Till An' Pak that this checklist is followed.

Initial Setup Checklist (prior to using for the first time)	
Location	Task
	Make sure the Till An' Pak is properly mounted to tractor hitch. Refer to "Attaching to Tractor" on page 14.
	Make sure all hardware is properly installed and tightened. Refer to "Maintenance Schedule" on page 16.
	Check the condition of the roller rings. Refer to "Ground Engaging Components" on page 17. Replace if necessary.

### Implement Break-In

Although there are no operational restrictions on the Till An' Pak when used for the first time, it is recommended that the following mechanical items be checked:

1. After 1/2 hour of operation:
  - a. Check all fasteners and tighten if necessary.
  - b. Make sure that the roller rings are in good condition.
2. After 10 hours of operation:
  - a. Go to the normal servicing and maintenance schedule, as defined in the Maintenance Section.

### General Operating Instructions

1. Familiarize yourself with the Operation and Parts Manual, and make sure the Till An' Pak is properly attached to the tractor before beginning work. Inspect the condition of the cutting edges and the overall Till An' Pak for potential problems or damage. Do not use the implement if it needs repairs of any type.
2. Clear the area of bystanders, especially small children. Make sure that you can clearly see and identify passersby, steep slopes, ditches, drop-offs, power lines, debris, and foreign objects. If you are unable to clearly see these type of items, discontinue operating the Till An' Pak.
3. Know the location of all underground cables, pipelines, and other hazards in the area. Also make certain that all irrigation heads, utility outlets, and other obstacles are properly marked.
4. Watch for low hanging limbs, power lines, and other overhead obstacles while you are operating. Use care to avoid hitting these items.
5. Do not operate the Till An' Pak, or drive the tractor into material that is burning, or areas that recently burnt and may contain hot spots. Tire damage can occur when driving over hot material. Oil and grease on the tractor and Till An' Pak could ignite, resulting in equipment destruction.
6. Lower the Till An' Pak to the ground and proceed forward at a speed of no more than 2 to 4 MPH. The Till An' Pak should immediately begin working soil surface.

7. Slow the tractor when making turns, and remember that the Till An' Pak is wider than the tractor when turning.
8. Always operate safely and follow all the instructions in this manual.

### Ring Roller Orientation

As shipped from the factory, Till An' Pak roller is set up in a "packing" orientation. If it is desired to use the Till An' Pak as a "tilling" tool, the ring roller must be reversed.

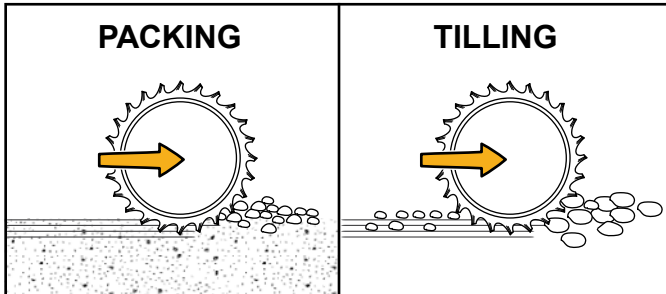

1. Remove tongue pin from Till An' Pak frame and slide tongue out.
2. Turn the tongue upside down and reinsert it into Till An' Pak frame tongue guide. Install tongue pin to secure the tongue.

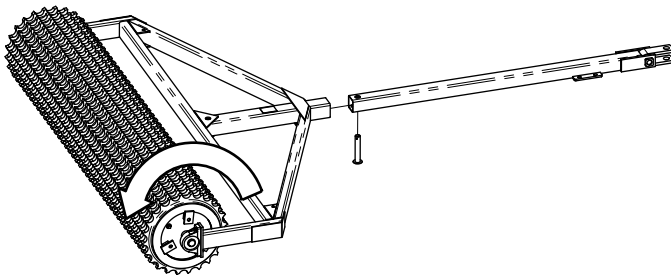
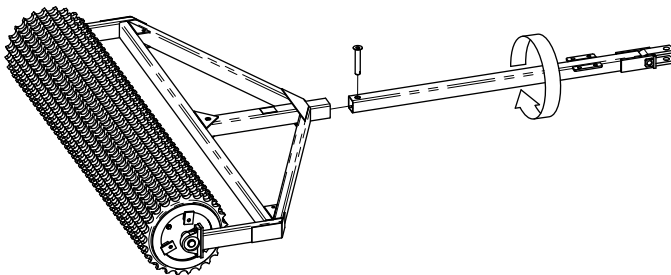

3. Rotate the tongue with the Till An' Pak frame around the roller to change direction of the roller.

### Detaching From Tractor

1. Move the Till An' Pak to a level storage location. Park the tractor, place the transmission in park or neutral, and apply the parking brake. Shut down the engine, and remove the key before exiting the tractor.
2. Make sure the Till An' Pak is resting securely on the ground or blocks before attempting to disconnect it from the tractor. Use extreme care to keep feet and hands from under the Till An' Pak and clear of any pinch points caused by the tractor hitch arms and Till An' Pak hitch pin.
3. Remove the pin from the Till An' Pak.
4. Disconnect the lift arms and drive the tractor away from the Till An' Pak.



## MAINTENANCE

 **WARNING**



**Understand Safety Procedures!**

Read and understand all safety procedures described in this manual before performing any work on or around the implement.

### Maintenance Schedule

The period recommended is based on normal operating conditions. Severe or unusual conditions may require more frequent service.

Hours and Serviced By																				
<b>Maintenance</b>																				
<b>Before Each Use or Daily</b>																				
Ensure that all fasteners are tight, and all pins are secured in place.																				
Inspect the frame for structural fractures.																				
Make sure all warning decals are in place and legible.																				
Check all rings for wear and damage. Replace if necessary.																				
<b>Every 50 Hours or Weekly</b>																				
Perform the Daily Maintenance schedule.																				
Lubricate zerk fittings on roller pillow block bearings with a good general purpose grease.																				
<b>Every 1000 Hours or Annually</b>																				
Perform the Daily Maintenance schedule.																				
Perform the Weekly Maintenance schedule.																				
Lubricate zerk fittings on roller pillow block bearings with a good general purpose grease.																				
Remove debris and clean the entire implement with compressed air or a pressure washer.																				
Remove rust and apply a coat of paint to frame surfaces where the paint has been worn off or damaged.																				

## Lubrication Points

Bearings come pre-lubed from the factory. Prior to applying grease, allow 40 hours of operation time to break in the seals. Add grease to the zerk fitting on the pillow block bearings on roller models, as shown. Avoid mixing different brands of grease.

**Note:** Clean the fitting, then add grease until it is visibly forced out of the bearing.

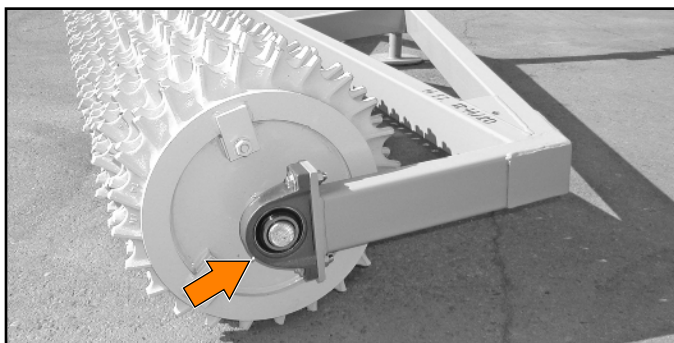

## Ground Engaging Components

Ground engaging components are subject to abrasion and wear. Excessively worn roller rings will require replacement.

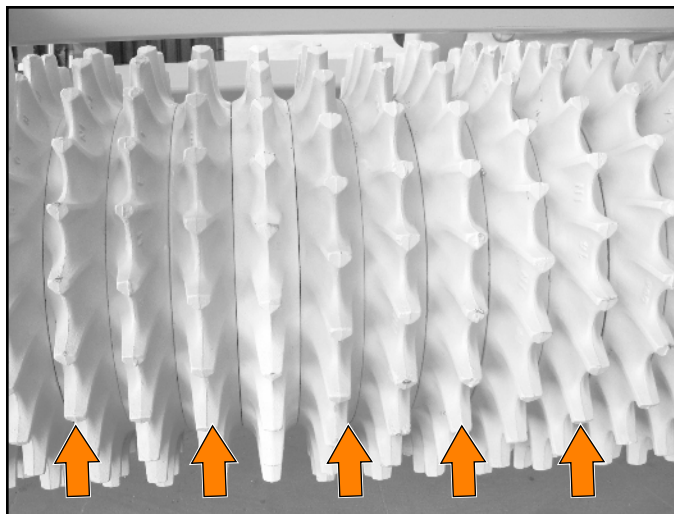

## STORAGE

### Storage Preparation

After work is completed for a season, perform the following maintenance procedures before storing the implement.

1. Apply a thin layer of grease or rust preventative to all exposed metal surfaces of the adjustable mechanisms (threaded rods, etc.).
2. Check all bolted connections. Ensure that the

fasteners are tight, and all retaining pins are secured in place with appropriate retaining clips.

3. Inspect the frame for structural fractures.
4. Check roller rings for wear and damage. If excessively worn or damaged, they must be replaced.
5. Make sure all the warning decals are in place and legible. Replace any worn decals as needed.
6. Thoroughly wash the Till An' Pak with a pressure washer or water hose to remove all dirt, mud, or debris.
7. Drain water from the roller tube (if applicable).
8. Lubricate the grease fittings on the roller pillow block bearings with a good general purpose lithium grease. Refer to "Lubrication Points" on page 17 for the location of the fittings.
9. To help prevent corrosion, remove rust and apply a coat of paint to frame surfaces where paint has been worn off or damaged.
10. Make sure the implement is stored in an area with a firm and level base to prevent it from tipping or sinking into the ground. For best results, always store the Till An' Pak in a dry, protected location. Leaving this implement unprotected will shorten the service life.

### Placing In Storage

1. Select an area that is dry, level, and free of debris (inside a building is ideal). Move the Till An' Pak to its storage area.
2. Disconnect the Till An' Pak from the tractor and drive the tractor away from the implement. Do not leave the tractor attached to the Till An' Pak.

### Removing From Storage

Prior to use each season, perform the following inspection and maintenance.

1. Read the operator's manual to review all safety, operational, and maintenance procedures.
2. Perform any recommended maintenance that was not completed when the implement was put into storage.
3. Visually inspect the implement for wear or damage.
4. Make sure all the warning decals are in place and legible. Replace any damaged or missing decals.
5. Attach the Till An' Pak to the tractor. Refer to "Attaching to Tractor" on page 14.

## PARTS SECTION

### Ordering Parts

We manufacture a quality product that requires very little maintenance or repair. However, should a part break become damaged, our knowledgeable staff can make sure you receive the part(s) to put your unit back into operation.

### Till An' Pak Assembly

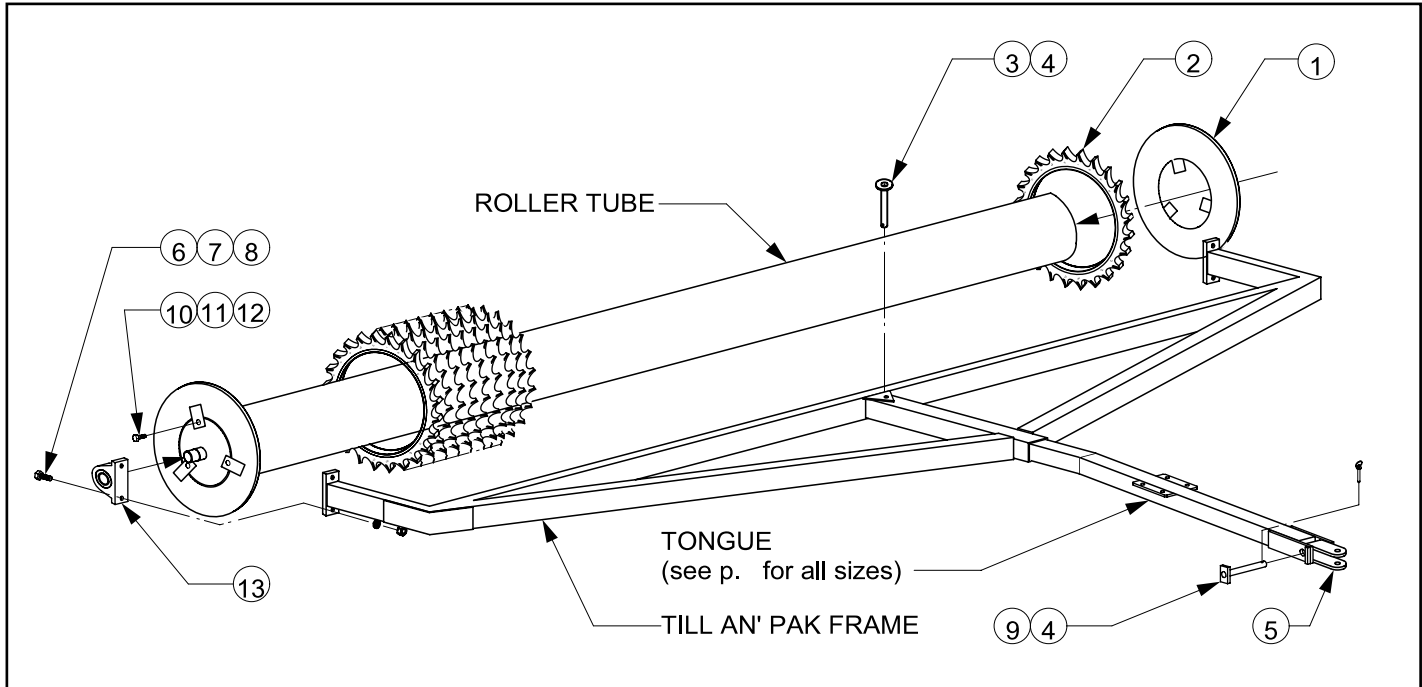

Item	Part Number	Description	Qty.
1	—	Till An' Pak Roller Retainer	2
2	—	Roller Ring	varies
3	TPP3010	Tongue Pin 1-1/8" x 6-1/2"	1
4	GPN-040LYN	1/4" Lynch Pin	2
5	TPP3020	3" Tongue Clevis	1
	TPP3021	3-1/2" Tongue Clevis	1
6	CSNC508036	1/2" X 2-1/4" NC Cap Screw (2'-15')	4
	CSNC510040	5/8" X 2-1/2" NC Cap Screw (16' & up)	4
7	LWASHER-08	1/2" Lock Washer (2'-15')	4
	LWASHER-10	5/8" Lock Washer (16' & up)	4
8	HXNUT-08NC	1/2" NC Hex Nut	4
	HXNUT-10NC	5/8" NC Hex Nut	4
9	TPP3025	TP Clevis Pin (2'-15')	1
	TPP3026	TP Clevis Pin (16' & up)	1
10	CBNC510020	5/8" X 1-1/4" NC Carriage Bolt	6
11	LWASHER-10	5/8" Lock Washer	6
12	HXNUT-10NC	5/8" NC Hex Nut	6
13	TPP3150	1-11/16" Pillow Block Bearing (2'-15')	2
	TPP3155	1-15/16" Pillow Block Bearing (16' & up)	2

### Smooth An' Roll Assembly

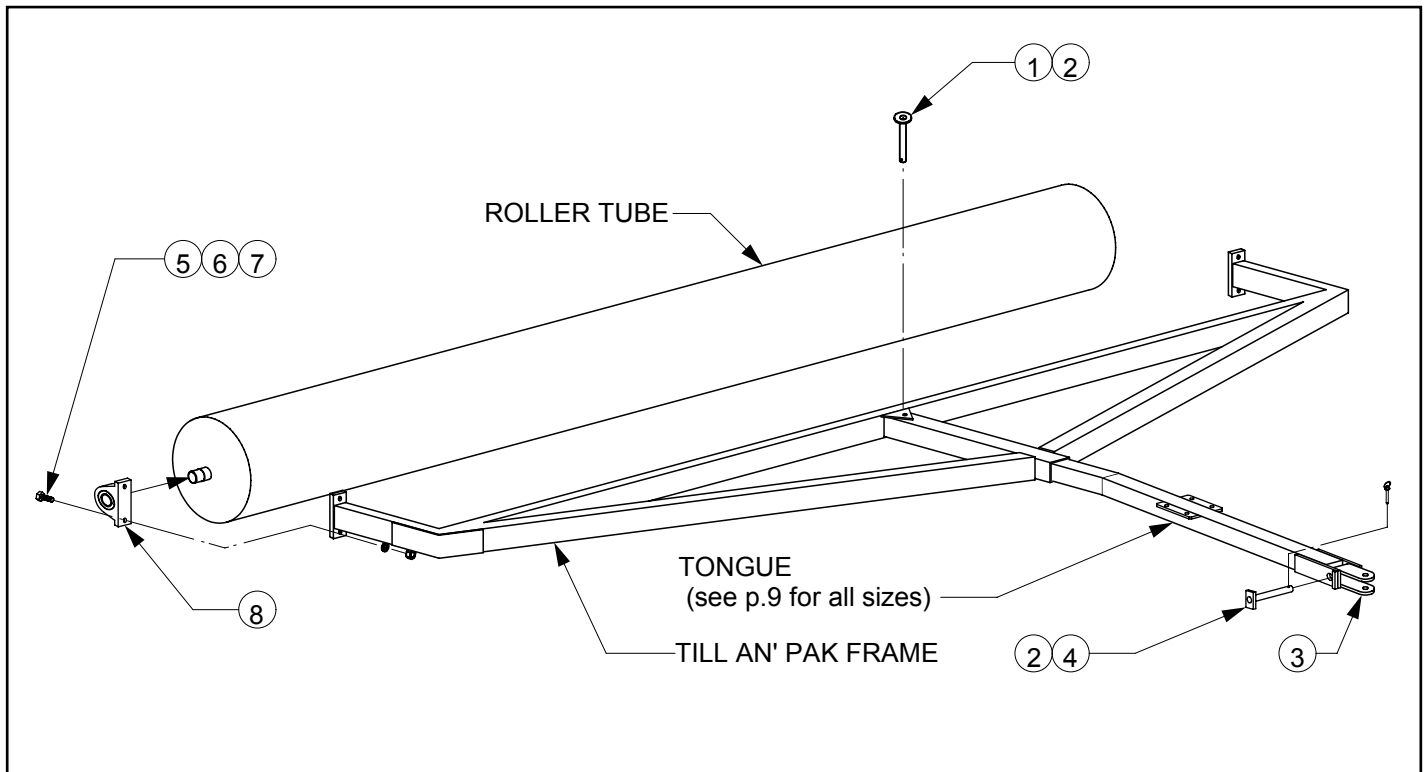

Item	Part Number	Description	Qty.
1	TPP3010	Tongue Pin 1-1/8" x 6-1/2"	1
2	GPN-040LYN	1/4" Lynch Pin	2
3	TPP3020	3" Tongue Clevis	1
	TPP3021	3-1/2" Tongue Clevis	1
4	TPP3025	TP Clevis Pin (2'-15')	1
	TPP3026	TP Clevis Pin (16' & up)	1
5	CSNC508036	1/2" X 2-1/4" NC Cap Screw (2'-15')	4
	CSNC510040	5/8" X 2-1/2" NC Cap Screw (16' & up)	4
6	LWASHER-08	1/2" Lock Washer (2'-15')	4
	LWASHER-10	5/8" Lock Washer (16' & up)	4
7	HXNUT-08NC	1/2" NC Hex Nut	4
	HXNUT-10NC	5/8" NC Hex Nut	4
8	TPP3150	1-11/16" Pillow Block Bearing (2'-15')	2
	TPP3155	1-15/16" Pillow Block Bearing (16' & up)	2

**Till An' Pak / Smooth An' Roll Tongues**

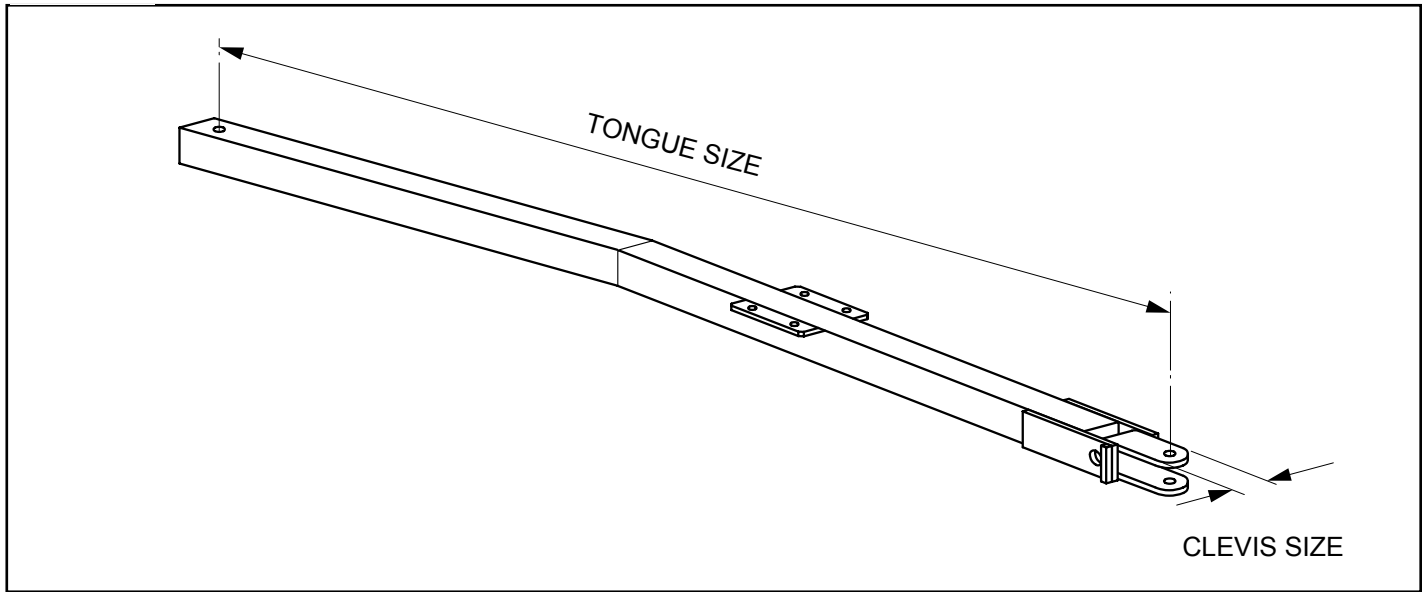

Unit Size	Clevis Size	Tongue Size	Tongue Part #
2' to 5'	3"	52"	TPP3001
6' to 9'	3"	72"	TPP3002
10' to 13'	3"	84"	TPP3003
14' to 18'	3-1/2"	84"	TPP3004
19' to 24'	3-1/2"	100"	TPP3005
19' to 24'	3-1/2"	100" - HD	TPP3005H
25' and Up	3-1/2"	120"	TPP3006
25' and Up	3-1/2"	144"	TPP3007

**Till An' Pak Tube, Ring, and Retainer Chart**

Tube Size	Ring Size (ID / OD)	Ring Part #	Retainer Size (ID - OD)	Retainer Part #
8"	10 / 14	TPP3350D	8 - 12	TPP3201
8"	12 / 16	TPP3351D	8 - 14	TPP3202
8"	13 / 17	TPP3352D	8 - 16	TPP3203
8"	14 / 20	TPP3353D	8 - 18	TPP3204
8"	16 / 22	TPP3354D	8 - 20	TPP3205
10"	12 / 16	TPP3351D	10 - 14	TPP3206
10"	13 / 17	TPP3352D	10 - 16	TPP3207
10"	14 / 20	TPP3353D	10 - 18	TPP3208
10"	16 / 22	TPP3354D	10 - 20	TPP3209
12"	14 / 20	TPP3353D	12 - 16	TPP3210
12"	16 / 22	TPP3354D	12 - 20	TPP3211
14"	16 / 22	TPP3354D	14 - 20	TPP3212

## Till An' Pak Accessories

### Float Assembly

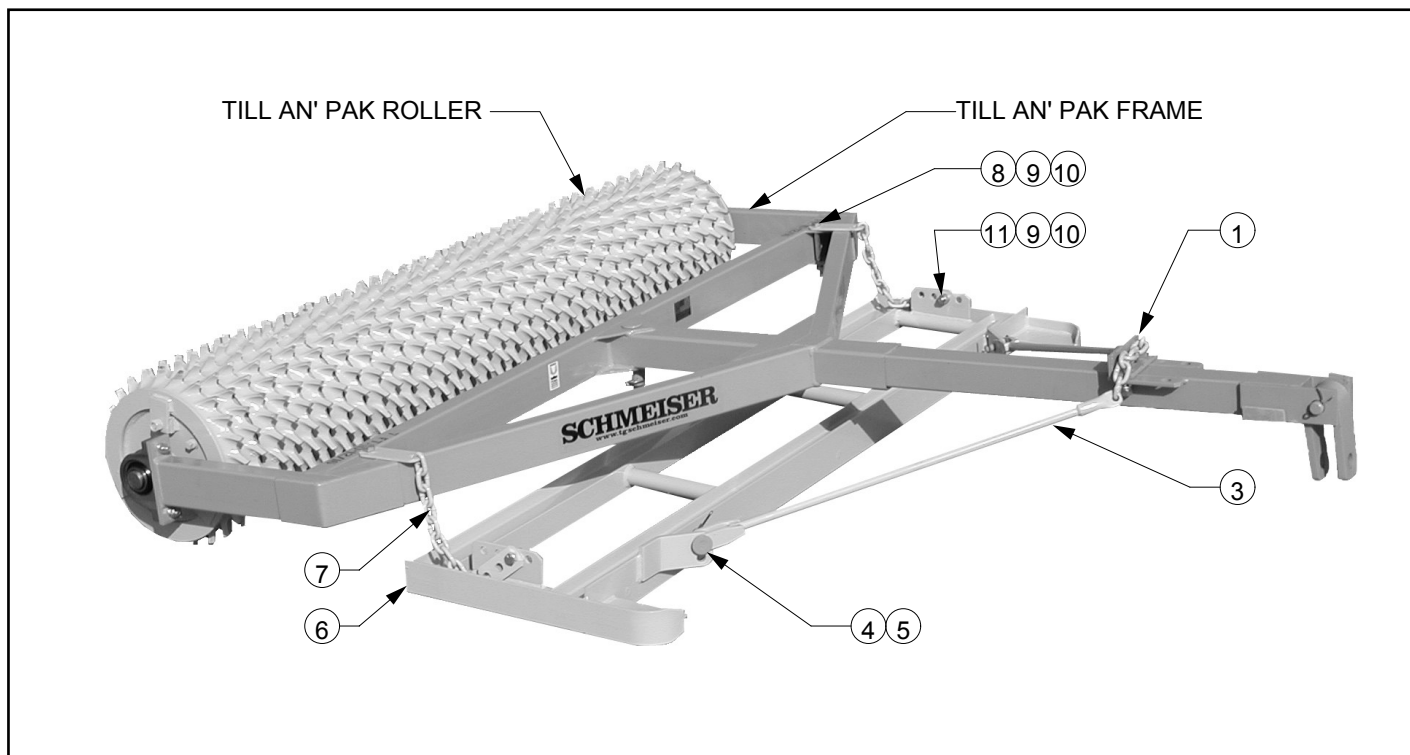

Item	Part Number	Description	Qty. Per Roller
1	TPF-01A014	Float Pull Bracket (2' to 13' units)	1
	TPF-02A014	Float Pull Bracket (14' and up)	1
3	TPF-04B000	Float Rods with Chain for 4' units - Pair	1
	TPF-05B000	Float Rods with Chain for 5' units - Pair	1
	TPF-06B000	Float Rods with Chain for 6' units - Pair	1
	TPF-07B000	Float Rods with Chain for 7'-12' units - Pair	1
	TPF-13B000	Float Rods with Chain for 13'-16' units - Pair	1
4	GPN-12X040	3/4" X 2-1/2" Standard Clevis Pin	2
5	GPN-04X040C	1/4" X 2-1/2" Cotter Pin	2
6	TPF-(00)C000	Float Main Frame (specify size)	1
7	TPF3502	Float Stay Chain	2
8	CSNC510096	5/8" X 6" NC Cap Screw	2
9	LWASHER-10	5/8" Lock Washer	6
10	HXNUT-10NC	5/8" NC Hex Nut	6
11	CSNC510024	5/8" X 1-1/2" NC Cap Screw	4

### Squadron Arms Assembly

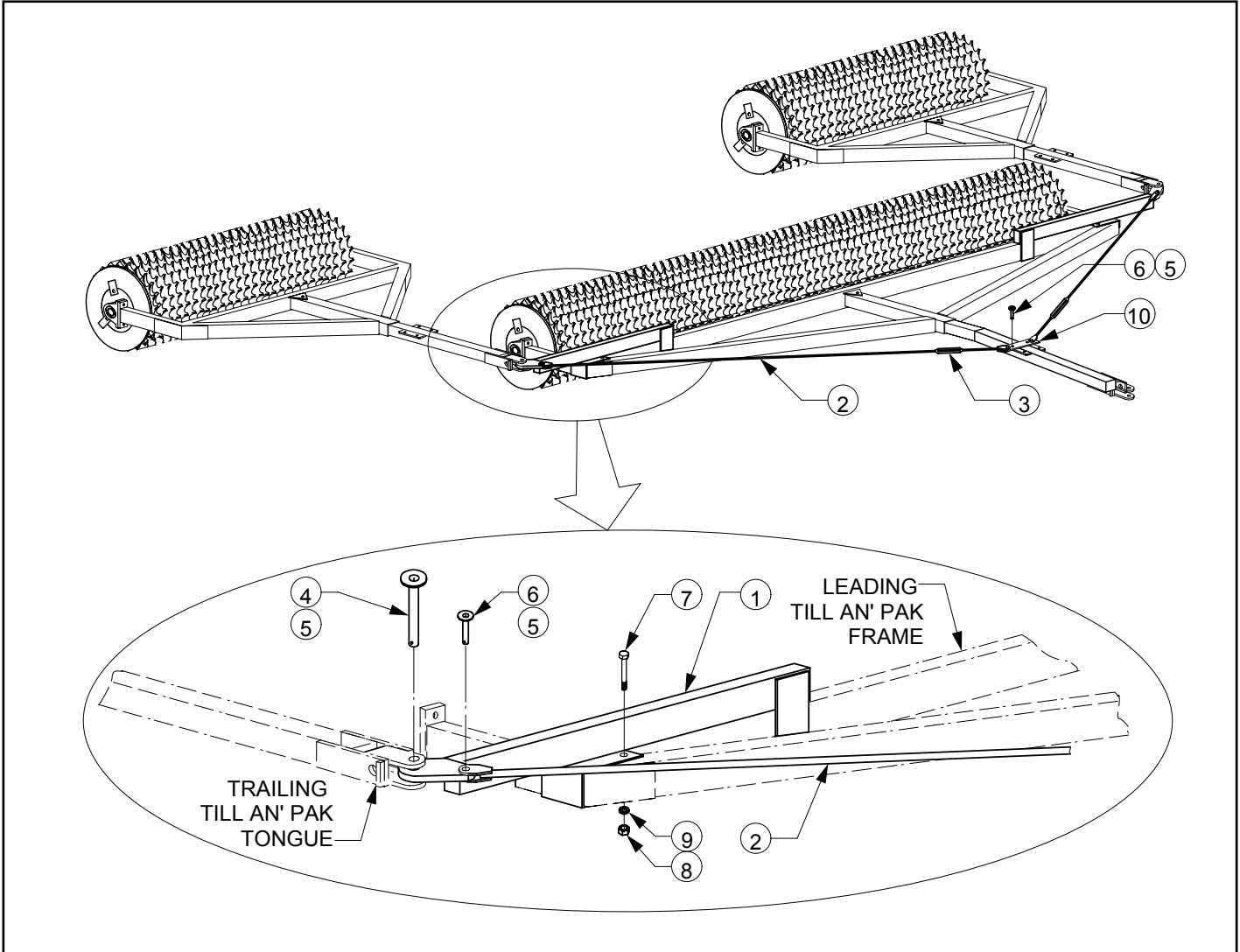

Item	Part Number	Description	Qty.
1	TPS-(00)D000	Squadron Arms Frame LH and RH (size)	1
2	TPS-00C000	Squadron Arm Turnbuckle Rod Long	2
3	GTB-12X96W	3/4" NC Turnbuckle Assembly	2
4	TPP3010	1-1/8" X 6" Tongue Pin	2
5	GPN-040LYN	1/4" Lynch Pin	4
6	GPN-12X040	3/4" X 2-1/2" Clevis Pin	2
7	CSNC510088	5/8" X 5-1/2" NC Cap Screw	2
8	HXNUT-10NC	5/8" NC Hex Nut	2
9	LWASHER-10	5/8" Lock Washer	2
	TPS-00A100	Tie Bar Bridge for 3" Tongues	1
	TPS-00A200	Tie Bar Bridge for 3-1/2" Tongues	1



**3-Point Hitch CA 1 & 2**

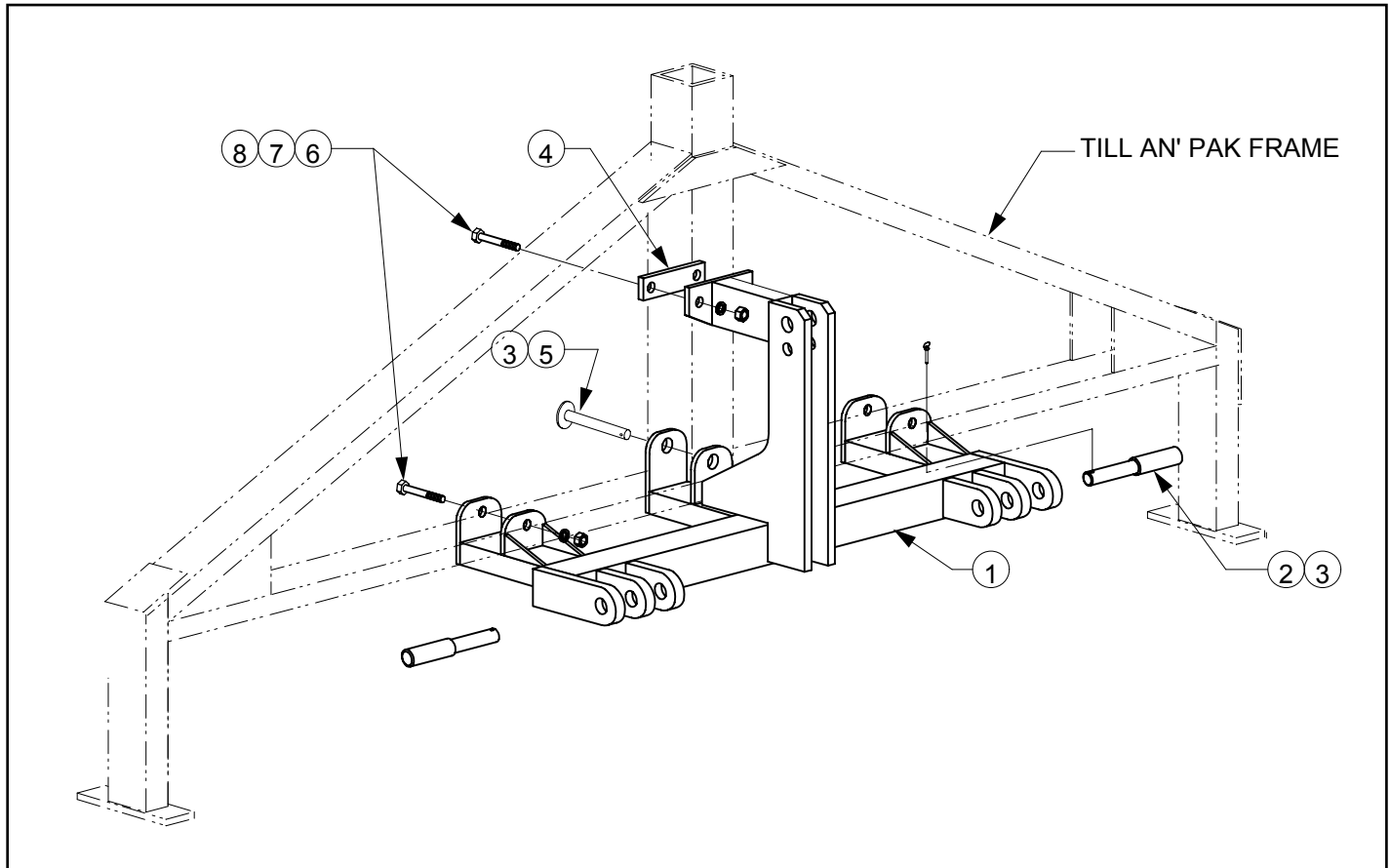

Item	Part Number	Description	Qty.
1	THS-00A000	Hitch Center Frame	1
2	GPN-18CA12	Category 1 & 2 Pull Pin	2
3	GPN-040LYN	1/4" Lynch Pin	2
4	THS-00A014	Clamp Plate	1
5	TPP3010	1-1/8" X 6" Tongue Pin	1
6	CSNC510112	5/8" X 6" NC Cap Screw	4
7	LWASHER-10	5/8" Lock Washer	4
8	HXNUT-10NC	5/8" NC Hex Nut	4

3-Point Hitch CA 2 & 3

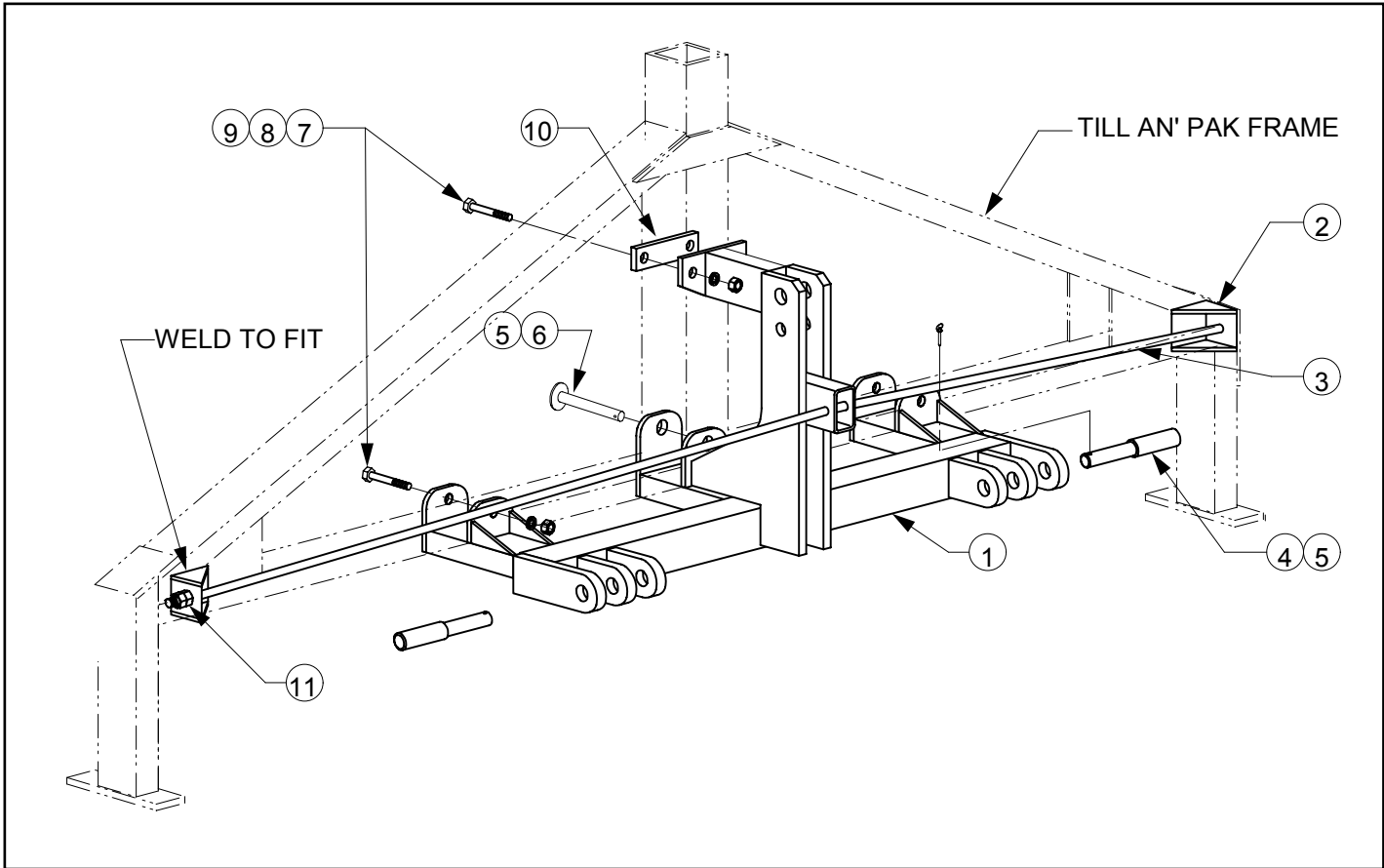

Item	Part Number	Description	Qty.
1	THH-00A100	HD Hitch Center Frame	1
2	THH-00A200	HD Hitch Truss Rod Mount	2
3	HRROUND12	3/4" HR Round (specify length)	1
4	GPN-24CA23	Category 2 & 3 Pull Pin	2
5	GPN-040LYN	1/4" Lynch Pin	2
6	TPP3010	1-1/8" X 6" TP Tongue Pin	1
7	CSNC510112	5/8" X 6" NC Cap Screw	4
8	LWASHER-10	5/8" Lock Washer	4
9	HXNUT-10NC	5/8" NC Hex Nut	4
10	THS-00A014	Clamp Plate	1
11	HXNUT-12NC	3/4" NC Hex Nut	4



## LIMITED WARRANTY STATEMENT

### T.G. Schmeiser Co., Inc.

P.O. Box 1392 – Selma, CA 93662  
Phone (559) 268-8128 Fax (559) 268-3279

T. G. Schmeiser Co., Inc. warrants each new Schmeiser® product to be free from defects in material and workmanship. This warranty is applicable only for the normal service life expectancy of the product or components, not to exceed twelve (12) consecutive months from the date of delivery of the new Schmeiser product to the original purchaser.

Genuine T. G. Schmeiser Co., Inc. replacement parts and components will be warranted for 90 days from date of purchase, or the remainder of the original equipment warranty period, whichever is longer.

Under no circumstances will it cover any merchandise or components thereof, which, in the opinion of the company, has been subjected to misuse, unauthorized modifications, alteration, an accident or if repairs have been made with parts other than those obtainable through T. G. Schmeiser Co., Inc.

The Company in no way warrants engines, batteries, cylinders, tires or other trade accessories since these items are warranted separately by their respective manufacturer. Expendable components such as points, shanks, blades, rings, bearings, teeth, and the like are excluded from this warranty.

Our obligation under this warranty shall be limited to repairing or replacing, free of charge to the original purchaser, any part that, in our judgment, shall show evidence of such defect, provided further that such part shall be returned within thirty (30) days from date of failure to T. G. Schmeiser Co., Inc., routed through the dealer and distributor from whom the purchase was made, transportation charges prepaid.

This warranty shall not be interpreted to render T. G. Schmeiser Co., Inc. liable for injury or damages of any kind or nature to person or property. This warranty does not extend to the loss of crops, loss because of delay in harvesting, or any expense or loss incurred for labor, substitute machinery, rental or for any other reason.

**Except as set forth above, T. G. Schmeiser Co., Inc. shall have no obligation or liability of any kind on account of any of its equipment and shall not be liable for special or consequential damages. T. G. Schmeiser Co., Inc. makes no other warranty, expressed or implied, and, specifically, T. G. Schmeiser Co., Inc. disclaims any implied warranty or merchantability or fitness for a particular purpose. Some states or provinces do not permit limitations or exclusions of implied warranties or incidental or consequential damages, so the limitations or exclusion in this warranty may not apply.**

This warranty is subject to any existing conditions of supply, which may directly affect our ability to obtain materials or manufacture replacement parts.

T. G. Schmeiser Co., Inc. reserves the right to make improvements in design or changes in specifications at any time, without incurring any obligation to owners of units previously sold.

No one is authorized to alter, modify or enlarge this warranty nor the exclusion, limitations and reservations.

**WARRANTY VOID IF NOT REGISTERED  
WITHIN 30 DAYS OF PURCHASE DATE**



**NOTES**



**NOTES**



**P.O. Box 1392  
Selma, CA 93662  
(559) 268-8128  
WEB: [www.TGSchmeiser.com](http://www.TGSchmeiser.com)**

